

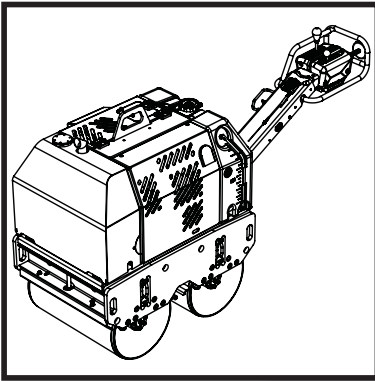

# BELLE TDX 650

870/10015/2  
08/19



- Spare Parts Book
- Pièces Détachées
- Libro Despiece
- Lista de Peças
- Onderdelen Boekje
- Reservedele Skrift
- Ersatzteilhandbuch
- Manuale dei Ricambi
- Bruksanvisning
- Varaosaluettelo
- Lista Części Zamiennych
- Запасные Части Книга
- Часть Списък
- Αντικατάσταση Κομμάτια Βιβλίο
- Část Barevný Pruh
- Részek Oldalra Dől
- Rezervni Djelovi Knjiga

**222**

(GB) Operators Manual	<b>6</b>
(US) Operators Manual	<b>18</b>
(F) Manuel De L'Opérateur	<b>30</b>
(E) Manual del Operador	<b>42</b>
(P) Manual de Operação	<b>54</b>
(NL) Handleiding	<b>66</b>
(DK) Betjeningsvejledning	<b>78</b>
(D) Bedienungshandbuch	<b>90</b>
(I) Manuale Dell'Operatore	<b>102</b>
(S) Bruksanvisning	<b>114</b>
(SF) Käyttöohje	<b>126</b>
(PL) Instrukcja Obsługi	<b>138</b>
(RUS) Руководство для оператора	<b>150</b>
(BG) Оператор Ръчен	<b>162</b>
(GR) χειριστής χειροποίητος	<b>174</b>
(CZ) Na'vod K Obzluze	<b>186</b>
(HUN) Kezelők Kézi	<b>198</b>
(HR) Uputstvo za rukovatelja	<b>210</b>

# EC DECLARATION OF CONFORMITY / DECLARATION CE DE CONFORMITE / DECLARACIÓN DE CONFORMIDAD CE / DECLARAÇÃO CE DE CONFORMIDADE / EG-VERKLARING VAN OVEREENSTEMMING / EF OVERENSSTEMMELSESERKLÆRING



We, **Belle Group Sheen UK, Sheen, Nr. Buxton, Derbyshire, SK17 0EU, GB**, hereby certify that if the product described within this certificate is bought from an authorised Belle Group dealer within the EEC, it conforms to the following EEC directives: 2006/42/CE (This directive replaces directive 98/37/EC), Electromagnetic Compatibility Directive 2004/108/CE (as amended by 89/336/EEC, 92/31/EEC & 93/68 EEC), The Waste Electrical and Electronic Equipment (WEEE) 2002/96/CE, the low voltage directive 2006/95/CE, BS EN ISO 12100-1:2003 Safety of machinery and associated harmonised standards, where applicable. Noise emissions conform to directives 2000/14/EC Annex VI & 2005/88/EC, for machines under article 12 the notified body is **AVT Reliability, Unit 2 Easter Court, Europa Boulevard, Warrington, Cheshire, WA5 7ZB, GB**  
**Noise Technical Files are held at the Belle Group Head Office address which is stated above.**



Nous soussignés, **Belle Group Sheen UK, Sheen, Nr. Buxton, Derbyshire, SK17 0EU, GB**, certifions que si le produit décrit dans ce certificat est acheté chez un distributeur autorisé Belle Group au sein de la CEE, il est conforme aux directives CEE ci-après: 2006/42/CE (Cette directive remplace la directive 98/37/CE), Directive compatible pour l'électromagnétisme 2004/108/CE (modifiée par 89/336/EEC, 92/31/EEC & 93/68 EEC). Les déchets électriques, et d'équipement électronique 2002/96/CE, caractéristiques basse tension 2006/95/CE, BS EN ISO 12100-1:2003 Directive de sécurité des machines et des critères associés et configurés, si applicable. Les émissions de bruit sont conformes à la directive 2000/14/CE Annexe VI et 2005/88/EC pour machines, article 12, l'objet mentionné est **AVT Reliability, Unit 2 Easter Court, Europa Boulevard, Warrington, Cheshire, WA5 7ZB, GB**  
**Les fichiers techniques des émissions sonores sont détenus par Ray Neilson à l'adresse du Siège du Groupe Belle qui est indiqué ci-dessus.**



La Sociedad, **Belle Group Sheen UK, Sheen, Nr. Buxton, Derbyshire, SK 17 0EU, GB**, por el presente documento certifica que si el producto descrito en este certificado es comprado a un distribuidor autorizado de Belle Group en la CEE, este es conforme a las siguientes directivas: 2006/42/CE de la CEE (Esta directiva sustituye a la Directiva 98/37/CE), Directiva 2004/108/CE sobre Compatibilidad Electromagnética (según enmiendas 89/336/EEC, 92/31/EEC & 93/68 EEC). Los residuos eléctricos y electrónicos (RAEE) 2002/96/CE, Directiva sobre Bajo Voltaje 2006/95/CE, BS EN ISO 12100-1:2003 de Seguridad de Maquinaria y Niveles armonizados estándares asociados donde sean aplicables. Emisión de Ruidos conforme a la Directiva 2000/14/CE Anexo VI y 2005/88/EC para máquinas bajo artículo 12 la mencionada unidad está **AVT Reliability, Unit 2 Easter Court, Europa Boulevard, Warrington, Cheshire, WA5 7ZB, GB**  
**En La Sede Central de Belle Group existen Archivos Técnicos con contenido referente a Niveles de Ruido.**



O signatário, **Belle Group Sheen UK, Sheen, Nr. Buxton, Derbyshire, SK 0EU, GB**, pelo presente, declara que se o produto descrito neste certificado foi adquirido a um distribuidor autorizado do Belle Group em qualquer país da UE, está em conformidade com o estabelecido nas seguintes diretivas comunitárias: 2006/42/CE (Esta directiva substitui a Directiva 98/37/CE), Directiva de Compatibilidade Electromagnética 2004/108/CE (conforme corrigido pelas 89/336/EEC, 92/31/EEC & 93/68 EEC). O Eléctrico de Desperdiço e Equipamento Electrónico (DEEE) 2002/96/CE, a directiva de baixa voltagem 2006/95/CE, BS EN ISO 12100-1:2003 Segurança da maquinaria e às normas harmonizadas afins se aplicáveis. As emissões de ruído respeitam e estão dentro das diretivas para máquinas 2000/14/CE Anexo VI & 2005/88/EC, artigo 12, sendo o organismo notificado **AVT Reliability, Unit 2 Easter Court, Europa Boulevard, Warrington, Cheshire, WA5 7ZB, GB**  
**A informação técnica sobre níveis sonoros está disponível na Sede da Belle Group na morada acima mencionada.**



Ondergetekende, **Belle Group Sheen UK, Sheen, Nr. Buxton, Derbyshire, SK17 0EU, GB**, verklaren hierbij dat als het product zoals beschreven in dit certificaat is gekocht van een erkende Belle Group dealer binnen de EEG, het voldoet aan de volgende EEG richtlijnen: 2006/42/CE (Deze richtlijn vervangt Richtlijn 98/37/EC), Electromagnetische Compatibiliteit Richtlijn 2004/108/CE (gesamendred door 89/336/EEC, 92/31/EEC & 93/68 EEC). De afgedankte elektrische en elektronische apparatuur (AEEA) 2002/96/CE, de Laagspannings Richtlijn 2006/95/CE, BS EN ISO 12100-1:2003 Veiligheid van Machines en hieraan gekoppelde geharmoniseerde Standaarden, waar deze van toepassing is. Geluidshinder te voldoen aan de richtlijnen 2000/14/EG en 2005/88/EG bijlage VI, voor toestel onder stuk 12 naar de notified troep zit **AVT Reliability, Unit 2 Easter Court, Europa Boulevard, Warrington, Cheshire, WA5 7ZB, GB**  
**Worden de Technische Dossiers van het lawaai gehouden op het adres van het Hoofdkantoor van de Groep Belle dat hierboven ' wordt verklaard.**



Vi, **Belle Group Sheen UK, Sheen, Nr. Buxton, Derbyshire, SK17 0EU, GB**, erklærer hermed, at hvis det i dette certifikat beskrevne produkt er købt hos en autoriseret Belle Group forhandler i EU, er det i overensstemmelse med følgende EØF-direktiver: 2006/42/CE (Dette direktiv erstatter direktiv 98/37/EF), 2004/108/EØF (som ændret ved 89/336/EEC, 92/31/EØF & 93/68 EØF), Afald af elektrisk og elektronisk udstyr (WEEE) 2002/96/CE, lavspændingsdirektiv 2006/95/CE, BS EN ISO 12100-1:2003 Maskinsikkerhed og tilhørende harmoniserede standarder, hvor det er relevant. Støjemission i overensstemmelse med direktiverne 2000/14/EF bilag VI og 2005/88/EF, for maskiner under paragraf 12. Det bemyndigede organ er **AVT Reliability, Unit 2 Easter Court, Europa Boulevard, Warrington, Cheshire, WA5 7ZB, GB**  
**De tekniske specifikationer forefindes på Belle Group's hovedkontor, adressen er skrevet ovenfor.**

PRODUCT TYPE .....	TYPE DE PRODUIT.....	TIPO DE PRODUCTO .....
MODEL.....	MODELE.....	MODELO.....
SERIAL No.....	N° DE SERIE.....	N° DE SERIE.....
DATE OF MANUFACTURE.....	DATE DE FABRICATION.....	FECHA DE FABRICACIÓN.....
SOUND POWER LEVEL MEASURED / .....	NIVEAU DE PUISSANCE SONORE MESUREE / .....	NIVEL DE POTENCIA ACÚSTICA MEDIDO / .....
.....(GUARANTEED)	.....(GARANTIE)	.....(GARANTIZADO)
WEIGHT.....	POIDS.....	PESO.....
TIPO DE PRODUCTO.....	PRODUCTTYPE.....	PRODUKTTYPE.....
MODELO.....	MODEL.....	MODEL.....
NO. DE SERIE.....	SERIENUMMER.....	SERIENR.....
DATA DE FABRIC.....	FABRICAGEDATUM.....	FREMSTILLINGSDATO.....
NIVEL DE POTENCIA DE SOM MEDIDO / .....	GEMETEN GELUIDSSTERKTENIVEAU / .....	LYDEFFEKTINVEAU MÅLT / .....
.....(GARANTIDO)	.....(GEGARANDEERD)	.....(GARANTERET)
PESO.....	GEWICHT.....	VÆGT.....



Signed by:  
 Signature:   
 Medido por:  
 Assinado por:  
 Getekend door:  
 Underskrevet af:  
**Ray Neilson**

**Managing Director - On behalf of BELLE GROUP (SHEEN) UK**  
**Le Directeur Général - Pour le compte de la SOCIETE BELLE GROUP (SHEEN) UK**  
**Director Gerente - En nombre de BELLE GROUP (SHEEN) UK**  
**Director-Geral - Em nome de BELLE GROUP (SHEEN) UK**  
**Algemeen Directeur - Namens BELLE GROUP (SHEEN) UK**  
**Administrerende direktør - På vegne af BELLE GROUP (SHEEN) UK**

**Place of Declaration** - Sheen, Nr. Buxton, Derbyshire, SK17 0EU, UK  
**Lieu de déclaration** - Sheen, Nr. Buxton, Derbyshire, SK17 0EU, UK  
**Declaración hecha en** - Sheen, Nr. Buxton, Derbyshire, SK17 0EU, UK  
**Lugar de Declaração** - Sheen, Nr. Buxton, Derbyshire, SK17 0EU, UK  
**Plaats van de Verklaring** - Sheen, Nr. Buxton, Derbyshire, SK17 0EU, UK  
**Sted i erklæring** - Sheen, Nr. Buxton, Derbyshire, SK17 0EU, UK

**Date of Declaration** - 2012 .....

**Date de déclaration** - 2012 .....

**Fecha de la declaración** - 2012 .....

**Data da Declaração** - 2012 .....

**Datum van de verklaring** - 2012 .....

**Dato for erklæringen** - 2012 .....

# EGKONFORMITÄTSERKLÄRUNG / DICHIARAZIONE CE DI CONFORMITÀ / EG-VERKLARING VAN OVEREENSTEMMING / EC SAMSVARSERKLÆRING / EY-YHDENMUKAISUUSILMOITUS / DEKLARACJA ZGODNOSCI Z PRZEPISAMI UE

**(D)** Wir, **Belle Group Sheen UK, Sheen, Nr. Buxton, Derbyshire, SK17 0EU, GB**, bestätigen hiermit, dass, wenn das Produkt innerhalb dieser Bescheinigung ist von einem gekauft zugelassen Belle Group-Händler innerhalb der EWG, so entspricht sie den folgenden EG-Richtlinien: 2006/42/CE (Diese Richtlinie ersetzt die Richtlinie 98/37/EG), elektromagnetische Kompatibilität Richtlinie 2004/108/EG (geändert durch 89/336/EWG, 92/31/EEG und 93/68 EWG), Die Elektro- und Elektronik-Altgeräte (WEEE) 2002/96/CE, der Niederspannungs-Richtlinie 2006/95/CE, BS EN ISO 12100-1:2003 Sicherheit von Maschinen und der damit verbundenen harmonisierten Normen, sofern zutreffend. Geräuschemissionen entsprechen der Richtlinie 2000/14/EG Anhang VI und 2005/88/EG, für Maschinen gemäß Artikel 12 der benannten Stelle ist **AVT Reliability, Unit 2 Easter Court, Europa Boulevard, Warrington, Cheshire, WA5 7ZB, GB**  
**Geräuschtechnische Dokumente stehen in unserer Zentrale unter obig angegebener Adresse zur Verfügung.**

**(I)** Il Gruppo Belle Sheen UK, Sheen, Nr. Buxton, Derbyshire, SK17 0EU, GB, certifica che, se il prodotto descritto nel presente certificato viene acquistato da un rivenditore autorizzato Belle gruppo all'interno della CEE, e conforme alle seguenti direttive CEE: 2006/42/CE (presente direttiva sostituisce la direttiva 98/37/CE), elettromagnetica compatibilità con la direttiva 2004/108/CE (modificata dalla 89/336/CEE, 92/31/CEE e 93/68 CEE). L'Elettrico di Spreco e l'Apparecchiatura Elettronica (WEEE) 2002/96/CE, la direttiva bassa tensione 2006/95/CE, BS EN ISO 12100-1:2003 Sicurezza del macchinario e le relative norme armonizzate, se del caso. Emissioni sonore conformi alla direttiva 2000/14/CE, allegato VI e 2005/88/EG, per le macchine a norma dell'articolo 12, l'organismo notificato **AVT Reliability, Unit 2 Easter Court, Europa Boulevard, Warrington, Cheshire, WA5 7ZB, GB**  
**Dati tecnici relativi ai livelli acustici sono disponibili su richiesta dalla sede madre Belle Group al sopra citato indirizzo.**

**(S)** Undertecknade, **Belle Group Sheen UK, Sheen, Nr. Buxton, Derbyshire, SK17 0EU, Storbritannien**, intygar härmed att om den produkt som beskrivs i detta intyg är köpt från en auktoriserad Belle-återförsäljare inom EEG, översensstämmer med följande EEG-direktiv: 2006/42/CE (Detta direktiv ersätter direktiv 98/37/EG). Elektromagnetisk kompatibilitet 2004/108/CE (ändrad genom direktiv 89/336/EEC, 92/31/EEG och 93/68 EEC). Avfall från elektriska och elektroniska produkter (WEEE) 2002/96/CE, lågsämningsdirektiv 2006/95/CE, BS EN ISO 12100-1:2003 Maskinsäkerhet och tillhörande harmoniserade standarder, i förekommande fall. Buller följa direktiv 2000/14/EG bilaga VI och 2005/88/EG till maskiner enligt artikel 12 anmälda organet är **AVT Reliability, Unit 2 Easter Court, Europa Boulevard, Warrington, Cheshire, WA5 7ZB, Storbritannien**.  
**Teknisk dokumentation vad gäller test av maskiners ljud/bullernivå finns dokumenterad hos Belle-Groups huvudkontor i Sheen, England.**

**(NO)** Vi, **Belle Group Sheen UK, Sheen, Nr. Buxton, Derbyshire, SK17 0EU, GB**, herved bekræfter at hvis produktet er beskrevet i dette certifikatet er kjøpt fra en autoriseret Belle Group forhandler innenfor EØS, følger det med til følgende EEC direktiver: 2006/42/CE (Dette direktivet erstatter direktiv 98/37/EE). Det elektromagnetisk kompatibilitets-direktiv 2004/108/CE (endret ved 89/336/EEC, 92/31/EEC og 93/68 EEC). Avfallset Elektrisk og Elektronisk Utstyr (WEEE) 2002/96/CE, Lavspenningsdirektiv 2006/95/CE, BS EN ISO 12100-1:2003 Sikkerhet av maskiner og tilhørende harmoniserte standarder, der dette er aktuelt. Lydeffekt samsvar med direktiv 2000/14/EG vedlegg VI og 2005/88/EG, for maskiner i henhold til artikkel 12 i meldte organ er **AVT Reliability, Unit 2 Easter Court, Europa Boulevard, Warrington, Cheshire, WA5 7ZB, GB**  
**Lydetekniske filer er arkivert hos Bell Group Hovedkontor med adresse som nevnt ovenfor.**

**(SF)** Me, **Belle Group Sheen UK, Sheen, Nr. Buxton, Derbyshire, SK17 0EU, GB**, todistaa, että jos tuote on kuvattu tämän todistuksen ostetaan valtuutetun Belle jälleenmyyjä ETY: n sisällä, se täyttää seuraavat EY-direktiivien: 2006/42/EY (tällä direktiivillä korvataan direktiivi 98/37/EY), sähkömagneettinen yhteensopivuutta direktiivin 2004/108/CE (muutettuna 89/336/ETY, 92/31/ETY ja 93/68 ETY). Tuhkaa Sähkö ja Sähköinen Varusteet (WEEE) 2002/96/CE, the matalajännittdirektiivistä 2006/95/CE, SFS-EN ISO 12100-1:2003 Koneturvallisuus ja niihin liittyvien yhdenmukaistettujen standardien tarvitessa. Melupäästöjä täyttävät direktiivin 2000/14/EY liitteessä VI ja 2005/88/EG, koneiden 12 artiklan mukaisesti ilmoitetun laitoksen on **AVT Reliability, Unit 2 Easter Court, Europa Boulevard, Warrington, Cheshire, WA5 7ZB, GB**  
**Melumittausten teknilliset arvot ovat saatavana Belle Group pääkonttorin ylläolevasta osoitteesta.**

**(PL)** My, **Belle Group Sheen UK, Sheen, Nr. Buxton, Derbyshire, SK17 0EU, Wielka Brytania**, niniejszym poświadczamy, iż produkt opisany w tym świadectwie został zakupiony od autoryzowanego Belle Group w UE i jest zgodny z następującymi dyrektywami UE: 2006/42/EY (Niniejsza dyrektywa zastępuje dyrektywę 98/37/EC). Dyrektywa zgodności elektromagnetycznej 2004/108/CE (z poprawkami wniesionymi przez 89/336/EEC, 92/31/EEC & 93/68 EEC). Utyżazanie sprzętu elektrycznego i elektronicznego 2002/96/CE, dyrektywa w sprawie niskich napięć 2006/95/CE, BS EN ISO 12100-1:2003 Bezpieczeństwo maszyn i związane normy harmonizacyjne, tam gdzie to ma zastosowanie. Poziom halasu jest zgodny z Dyrektywą 2000/14/EC Załącznik VI i 2005/88/EG, organizacja zawiadaniama (odnośnie zgodności) to **AVT Reliability, Unit 2 Easter Court, Europa Boulevard, Warrington, Cheshire, WA5 7ZB, Wielka Brytania**.  
**Informacje Techniczne dotyczące poziomu hałasu są przechowywane w Belle Group – adres powyżej.**

PRODUKTTYP.....	TIPO PRODOTTO .....	PRODUKTTYP.....
MODELL .....	MODELLO .....	MODELL .....
SERIENNR.....	SERIE N°.....	SERIE NR .....
HERSTELLUNGSDATU .....	DATA DI FABBRICAZIONE..	TILLVERKNINGSDATUM.....
SCHALLLEISTUNGSPEGEL GEMESSEN / .....	LIVELLO POTENZA SONORA MISURATA / .....	LJUDSTYRKA UPPMÄTT / .....
.....(GARANTIERT)	.....(GARANTITA)	.....(GARANTERAD)
GEWICHT.....	PESO .....	VIKT.....
PRODUKTTYP.....	TUOTETYYPPI .....	TYP PRODUKTO.....
MODELL .....	MALLI .....	MODEL .....
SERIE NR .....	VALMISTUSNRO .....	Nr SERII.....
PRODUKSJONS DATO.....	VALMISTUSPÄIVÄ .....	DATAPRODUKCIJ .....
ÄLYDKRAFTNIVÅ MÅLT / .....	ÄNENVOIMAKKUUDEN TASO MITATTU / .....	POZIOM MOCY DŹWIĘKU ZMIERZONY / .....
.....(GARANTERT)	.....(TAATTU)	.....(GWARANTOWANY)
VEKT.....	MASSA .....	WAGA.....



Unterzeichnet von:  
 Firmato da:  
 Undertecknat:  
 Signatur:  
 Allekirjoitus:  
 Podpisal:  
  
**Ray Neilson**

**Generaldirektor – Im auftrag von BELLE GROUP (SHEEN) UK.**  
**Administratore Delegato – Per conto di BELLE GROUP (SHEEN) UK.**  
**V.D. – På vägnar av BELLE GROUP (SHEEN) UK.**  
**Managing Director – På vegne av SOCIETE BELLE GROUP (SHEEN) UK.**  
**Toimitusjohtaja - BELLE GROUP (SHEEN) UK: n puolesta.**  
**Dyrektor Zarządzający – w imieniu BELLE GROUP (SHEEN) UK**

**Erklärungsort - Sheen, Nr. Buxton, Derbyshire, SK17 0EU, UK**  
**Luogo de dichiarazione - Sheen, Nr. Buxton, Derbyshire, SK17 0EU, UK**  
**Plats av Förklaring - Sheen, Nr. Buxton, Derbyshire, SK17 0EU, UK**  
**Sted av Erklaring - Sheen, Nr. Buxton, Derbyshire, SK17 0EU, UK**  
**Julistuksen paikka - Sheen, Nr. Buxton, Derbyshire, SK17 0EU, UK**  
**Miejsce deklaracji - Sheen, Nr. Buxton, Derbyshire, SK17 0EU, UK**

**Erklärungsdatum - 2012.....**  
**Data de dichiarazione - 2012.....**  
**Datum av Förklaring - 2012.....**  
**Dato av Erklaring - 2012.....**  
**Julistuksen päivämäärä - 2012.....**  
**Data deklaracji - 2012.....**

**СЕРТИФИКАТ СООТВЕТСТВИЯ / EÜ VASTAVUSDEKLARATSIOON / ATBILSTĪBAS DEKLARĀCIJA / ES ATĪTIKTIES DEKLARACIJA / ДЕКЛАРАЦИЯ ЗА СПАЗВАНЕ НА ИЗИСКВАНИЯ / ΕΕ ΔΗΛΩΣΗ ΚΑΤΑΛΛΗΛΟΤΗΤΑΣ**



Мы, нижеподписавшиеся, от имени Belle Group Sheen (Великобритания), Sheen, Nr. Buxton, Derbyshire SK17 0EU, Великобритания, заявляем, что в случае, если описанная в данном сертификате продукция была приобретена у уполномоченного представителя Белле Групп в ЕС, то она соответствует следующим директивам ЕС: 2006/42/CE (Эта директива заменяет директиву 98/37/ЕЕС), директиве электромагнитной совместимости 2004/108/CE (дополненной 89/336/ЕЕС, 92/31/ЕЕС & 93/68 ЕЕС), Утилизации электрического и электронного оборудования (WEEE) 2002/96/CE, 2006/95/CE Директива низкого напряжения, BS EN ISO 12100-1:2003 Безопасность машин и связанные с ними гармонизированных стандартов, где это применимо. Уровень шума соответствует директивам 2000/14/EC Приложение VI в 2005/88/EC, для машин, указанных в статье 12 уполномоченный орган: **AVT Reliability, Unit 2 Easter Court, Europa Boulevard, Warrington, Cheshire, WA5 7ZB, GB**  
Шум технических файлов хранятся Рай Нейлсон на руководителя группы Belle Управления адрес, который указан выше.



Meie, Belle Group Sheen UK, Sheen, Nr Buxton, Derbyshire, SK17 0EU, GB, kinnitan, et kui kirjeldatud toote jooksul käesoleva sertifikaadi on ostetud lubatud Belle nimele vahendaja jooksul EMU, see vastab järgmistele EMÜ direktiividele: 2006/42/CE (käesolev direktiiv asendab direktiivi 98/37/EÜ), elektromagnetilise ühilduvuse direktiivi 2004/108/CE (muudetud 89/336/EMÜ, 92/31/EEB ja 93/68 EMÜ). Ja elektroonikaseadmete jäätmete (WEEE) 2002/96/CE, madalpinge direktiivi 2006/95/CE, BS EN ISO 12100-1:2003 Masinate ohutus ning sellega seotud ühtlustatud standarditele, kui see on kohaldatav. Müra osas vastama direktiivi 2000/14/EÜ VI lisa ja 2005/88/EÜ masinate artikli 12 kohaselt teavitatud asutus on **AVT Reliability, Unit 2 Easter Court, Europa Boulevard, Warrington, Cheshire, WA5 7ZB, GB**  
**Müra Tehniline failid hoitakse Ray Neilson kell Belle grupi peakontor aadressil, mis on märgitud eespool.**



Mēs, Belle Group Sheen UK, Nr. Buxton, Derbyshire, SK17 0EU, ar šo apliecinām, ar šo apliecinu, ka gadījumā, ja produkts aprakstīts šajā sertifikātā ir iegādājies no pilnvarotā Belle grupas dileru teritorijā EEK, tā atbilst šādām EK direktīvām: 2006/42/CE (Šī direktīva aizvieto Direktīvu 98/37/EK), Elektromagnētiskās saderības direktīvu 2004/108/CE (kurā grozījumi izdarīti ar 89/336/EEK, 92/31/EEK un 93/68 EEK), Elektrisko un elektronisko iekārtu atkritumiem (EIA), 2002/96/CE, zemsprieguma direktīvu 2006/95/CE, BS EN ISO 12100-1:2003 Mašīnu drošība un saistītos saskaņotus standartus, ja vajadzīgs. Trokšņa emisijas neatbilst Direktīvas 2000/14/EK VI pielikumā un 2005/88/EK, mašīnu saskaņā ar 12 pilnvarotā iestāde ir **AVT Reliability, Unit 2 Easter Court, Europa Boulevard, Warrington, Cheshire, WA5 7ZB, LIELBRITĀNIJA**.  
**Trokšņa Tehniskās faili tur Ray Neilson pie Belle grupas galvenā biroja adrese, kas norādīts iepriekš.**



Mēs, Belle Group Sheen UK, Sheen, Nr Buxton, Derbyshire, SK 0EU, GB, patvirtinu, kad jei produktas, kaip aprašyta šio sertifikato pirkty iš leidžiama Belle frakcijos atstovas pagal EEB, jis atitinka šiuos EEB direktyvas: 2006/42/CE (ši direktyva pakeičia Direktyvą 98/37/EB), elektromagnetinio suderinamumo direktyvos 2004/108/CE (su pakeitimais, padarytais 89/336/EEB, 92/31/EEB ir 93/68 EEB). Elektros ir elektroninės įrangos atliekų (EEJ atliekų), 2002/96/CE, Žemosios įtampos įrangos direktyvą 2006/95/CE, LST EN ISO 12100-1:2003 Mašinių sauga ir susiję dariniai standartai, jei taikytina. Triukšmo emisija neatitinka Direktyvos 2000/14/EB VI priede UN 2005/88/EB, už mašinos pagal 12 straipsnio nuostatas, notifikuoti įstaiga yra **AVT Reliability, Unit 2 Easter Court, Europa Boulevard, Warrington, Cheshire, WA5 7ZB, GB**  
**Triukšmo Techniniai failai vyks Ray Neilson Belle grupės buveinės adresu, kuris nurodytas aukščiau.**



Компанията, Belle Group Sheen UK, Sheen, Nr. Buxton, Derbyshire, SK17 0EU, GB, се удостоверява, че ако стоката е описано в този сертификат е закупен от авторизиран дилър Belle група в рамките на ЕИО, то отговаря на следните директиви на ЕИО: 2006/42/CE (настоящата директива заменя Директива 98/37/ЕО), електромагнитна съвместимост Директива 2004/108/CE (както е изменен с 89/336/ЕО, 92/31/ЕО и 93/68 ЕО). За отпадъците от електрическо и електронно оборудване (ОЕО), 2002/96/CE, ниското напрежение директива 2006/95/CE, BS EN ISO 12100-1:2003 Безопасност на машините и свързаните с тях хармонизирани стандарти, когато е приложимо. Шум емисии съответства на Директива 2000/14/ЕО приложение VI и 2005/88/ЕО, за машини, съгласно член 12 на нотифицирани орган е **AVT Reliability, Unit 2 Easter Court, Europa Boulevard, Warrington, Cheshire, WA5 7ZB, GB**  
**Шум Технически файлове се провеждат от Рай Нийлсън в групата адрес Belle централното управление, което е посочено по-горе.**



Εμείς, η Belle Group, Sheen UK, Sheen, Nr. Buxton, Derbyshire, SK17 0EU, Μεγάλη Βρετανία, βεβαιώνω ότι, αν το προϊόν που περιγράφεται σε αυτό το πιστοποιητικό έχει αγοράσει από εξουσιοδοτημένο αντιπρόσωπο Belle ομάδα στο εσωτερικό της ΕΟΚ, θα συμμορφώνεται με τη ακόλουθη οδηγία ΕΟΚ: 2006/42/CE (Η παρούσα οδηγία αντικαθιστά τη οδηγία 98/37/ΕΚ). Ηλεκτρομαγνητική Συμβατότητα οδηγία 2004/108/CE (όπως τροποποιήθηκε από την 89/336/ΕΟΚ, 92/31/ΕΟΚ και 93/68 ΕΟΚ). Τα Αποβλήτα Ηλεκτρικού και Ηλεκτρονικού Εξοπλισμού (ΑΗΝΕ) 2002/96/CE, Η οδηγία 2006/95/CE χαμηλής τάσης, BS EN ISO 12100-1:2003 Ασφάλεια μηχανών και των σχετικών ενσωματωμένων προτύπων, ανάλογα με την περίπτωση, ΕΚπομπές θορύβου σύμφωνα με την οδηγία 2000/14/ΕΚ παράρτημα VI και 2005/88/ΕΚ, για τις μηχανές σύμφωνα με το άρθρο 12 του κοινοποιημένου οργανισμού του είναι: **AVT Reliability, Unit 2 Easter Court, Europa Boulevard, Warrington, Cheshire, WA5 7ZB, GB**  
**Οι θορύβου Τεχνικά αρχεία που κατέχονται από Ray Neilson στην ομάδα Belle Διεύθυνση έδρας του αναφέρεται παραπάνω.**

ТИП ПРОДУКЦИИ.....	TOOTE TÛUP.....	PRODUKTA TIPS.....
МОДЕЛЬ.....	MUDEL.....	MODELIS.....
СЕРИЙНЫЙ НОМЕР.....	SERIANUMBER.....	SĒRIJAS NR.....
ДАТА ВЫПУСКА.....	VALMISTAMISE KUUPÄEV.....	IZGATAVOŠANAS DATUMS.....
УРОВЕНЬ ШУМА ЗАМЕР ПРОИЗВЕДЕН / .....(ГАРАНТУИРА)	HELITUGUVUSE TASE MÕÕDETUD / .....(GARANTEERITUD)	IZMĒRĪTAIS SKAŅAS JAUDAS LĪMENIS / .....(GARANTĒTAIS)
ЧАСТОТА.....	KAAL.....	MASA.....
GAMINIO TIPAS.....	ВИД НА ПРОДУКТА.....	Τύπος προϊόντος.....
MODELIS.....	ΜΟΔΕΛ.....	Μοντέλο.....
SĒRIJOS NR.....	СЕРИЕН НОМЕР.....	Αριθμός Σειράς.....
PAGAMINIMO DATA.....	ДАТА НА ПРОИЗВОДСТВО.....	Μετρημένη.....
GARSO STIPRUMO LYGIS IŠMATUOTAS / .....(GARANTUOTAS)	НИВО НА СИЛАТА НА ЗВУКА ИЗΜΕΡΕНО / .....(ΓΑΡΑΝΤΙΡΑΗΟ)	Σταθμή Θορύβου Κατα Την Ημερομηνία Κατασκευής / (Εγγυημένη)
SVORIS.....	ТЕΟЯΛ.....	Βάρος.....



Подпись:  
Alla kirjutanud:  
Paraksts:  
Pasiraše:  
Подпис:  
Υπογραφή:  
  
**Ray Neilson**

исполнительный директор - от имени БЕЛЛЕ ГРУП ШИИН (ВЕЛКОБРИТАНИЯ).  
Tevgevdirektor - BELLE GROUP (SHEEN) UK pool.  
Vadošais direktors - Pārstāvot BELLE GROUP (SHEEN) UK.  
Generalinis direktorius - BELLE GROUP (SHEEN) UK vardu.  
Рей Нийлсън - Управляващ директор от името на BELLE GROUP (SHEEN) UK.  
Διευθύνων Σύμβουλος - εκ μέρους της BELLE GROUP (SHEEN) Μεγάλη Βρετανία.

Место декларирования - Sheen, Nr. Buxton, Derbyshire, SK17 0EU, UK  
Kohat deklaratsiooni - Sheen, Nr. Buxton, Derbyshire, SK17 0EU, UK  
Vieta deklarāciju - Sheen, Nr. Buxton, Derbyshire, SK17 0EU, UK  
Vieta deklarācijas - Sheen, Nr. Buxton, Derbyshire, SK17 0EU, UK  
Дата на декларация - Sheen, Nr. Buxton, Derbyshire, SK17 0EU, UK  
Τόπος Διακήρυξης - Sheen, Nr. Buxton, Derbyshire, SK17 0EU, UK

Дата декларирования - 2012.....  
Deklaratsiooni kuupäev - 2012.....  
Dienas deklarācija - 2012.....  
Data deklarācijas - 2012.....  
Място на декларация - 2012.....  
Ημερομηνία δήλωσης - 2012.....

**ES PROHLÁŠENÍ O SHODĚ / DECLARATIE DE CONFORMITATE CE /  
EU MEGFELELŐSÉGI NYILATKOZAT / EC UYUM BİLDİRGESİ / EC IZJAVA O USKLAĐENOSTI /  
PREHLÁSENIE O ZHODE**



My, **Belle Group Sheen UK, Sheen, Nr. Buxton, Derbyshire, SK17 0EU, Velké Británie**, potvrzují, že v případě výrobků uvedených v tomto osvědčení je koupil od autorizovaného dealera Belle skupinu v rámci EHS, že splňuje následující směrnice EHS: 2006/42/CE (tato směrnice nahrazuje směrnici 98/37/ES) (Elektromagnetická kompatibilita Směrnice 2004/108/CE ve znění 89/336/EEC, 92/31/EEC & 93/68 EHS). Odpadních elektrických a elektronických zařízeních (OEEZ), 2002/96/CE, nízkonapětové směrnice 2006/95/CE, BS EN ISO 12100-1:2003 Bezpečnost strojních zařízení a související harmonizované normy, popřípadě. Hlukových emisí v souladu se směrnicí 2000/14/ES příloha VI a 2005/88/ES, pro stroje podle článku 12 oznámený subjekt **AVT Reliability, Unit 2 Easter Court, Europa Boulevard, Warrington, Cheshire, WA5 7ZB, Velká Británie**.  
**Hluk Technické soubory jsou drženy Ray Neilson v sídle skupiny Belle Office adresu, která je uvedeno výše.**



Noi, **Belle Group Sheen UK, Sheen, Nr. Buxton, Derbyshire, SK17 0EU, GB**, certific prin prezenta că în cazul în care produsul descris în cadrul acestui certificat este comercializat de la un distribuitor autorizat Belle Group în cadrul CEE, este conformă cu următoarele directive CEE: 2006/42/CE (prezenta directivă înlocuiește Directiva 98/37/CE), de compatibilitate electromagnetică a Directivei 2004/108/CE (astfel cum a fost modificată prin 89/336/CEE, 92/31/CEE și 93/68 CEE). Deșeurile electrice și electronice (DEEE) 2002/96/CE, tensiune scăzută a Directivei 2006/95/CE, BS EN ISO 12100-1:2003 Securitatea mașinilor și asociate standardele armonizate, acolo unde este cazul. A emișilor de zgomot în conformitate cu Directiva 2000/14/CE anexa VI & 2005/88/CE, pentru mașini în temeiul articolului 12 organismul notificat este **AVT Reliability, Unit 2 Easter Court, Europa Boulevard, Warrington, Cheshire, WA5 7ZB, GB**.  
**Fișierele de zgomot tehnice sunt deținute de către Ray Neilson la adresa șefului de grup Belle Oficial pentru care este menționat mai sus.**



Mi, a **Belle Group Sheen UK, Sheen, Nr. Buxton, Derbyshire, SK17 0EU, Egyesült Királyság** ezúton igazolom, hogy ha a termék leírása belől ezt a bizonyítványt vásárolt engedélyezett Belle Group kereskedő az EKG, az megfelel az alábbi EEC irányelveknek: 2006/42/CE (ez az irányelv felváltja a 98/37/EK irányelvet), elektromágneses kompatibilitási irányelv 2004/108/CE (módosított 89/336/EKG, 92/31/EKG és 93/68 EKG). A hulladék elektromos és elektronikus berendezések (WEEE) 2002/96/CE, kisfeszültség irányelv 2006/95/CE, BS EN ISO 12100-1:2003 Gépek biztonságja és a kapcsolódó harmonizált szabványok, adott esetben. Zajkibocsátás megfelel a 2000/14/EK irányelv VI és 2005/88/EK gépész a 12. cikk alapján a bejelentett szervezet: **AVT Reliability, Unit 2 Easter Court, Europa Boulevard, Warrington, Cheshire, WA5 7ZB, Egyesült Királyság**.  
**Zaj mûszaki fájlokak birtokában Ray Neilson, a Belle-csoport központi iroda címet, amely a fenti.**



Mi, **Belle Group Sheen UK, Sheen, Nr. Buxton, Derbyshire, SK17 0EU, GB**, ovime potvrđujem da ako proizvod opisan unutar ovog certifikata je kupio od Belle Group ovlaštenog distributera unutar EEZ, ona odgovara sljedećim EEC smjernica: 2006/42/CE (Ova direktiva zamjenjuje direktiva 98/37/CE), Elektromagnetska kompatibilnost Direktiva 2004/108/CE (kako je izmijenjeno 89/336/EEC, 92/31/EEC / 93/68 EEC). Otpad električne i elektroničke opreme (WEEE) 2002/96/CE, niskonaponske direktivi 2006/95/CE, BS EN ISO 12100-1:2003 Sigurnost strojeva i pridružene usklađene standarde, gdje je primjenjivo. Emisija buke u skladu s direktivom 2000/14/EC Anexa VI & 2005/88/EC, za strojeve iz članka 12. obavješteni tijelo **AVT Reliability, Unit 2 Easter Court, Europa Boulevard, Warrington, Cheshire, WA5 7ZB, GB**.  
**Buka Tehnički datoteke drže Ray Neilson na Glavnom Belle grupe Office adresu koja je navedeno gore.**



Biz, **Belle Group Sheen UK, Sheen, Nr. Buxton, Derbyshire, SK17 0EU, GB**, Belle Group Eđer ürün bu sertifikayı içinde açıklanan burada da tasdik AET içinde yetkili Belle Grup diler satın ođduğundan, aşağıdaki AET direktiflerine uyumludur: 2006/42/CE (Bu yönerge yönetmesi 98/37/EC yeline). Elektromanyetik Uyumluluk Yönetmeliği 2004/108/CE (as 89/336/EEC, 92/31/EEC ve 93/68 AET tarafından) değiştirilmiştir. Atık Elektrikli ve Elektronik Ekipman (WEEE) 2002/96/CE, alçak gerilim direktifi 2006/95/CE, BS EN ISO 12100-1:2003 Makine Güvenliği ve ilgili uyumlaştırılmış standartlar, uygulanabilir Onaylanmış kuruluş, madde 12 altında makineleri için, gürtütlü emisyonları direktifleri 2000/14/EC Ek VI ve 2005/88/EC ile uyumlu **AVT Reliability, Unit 2 Easter Court, Europa Boulevard, Warrington, Cheshire, WA5 7ZB, GB**.  
**Gürtütlü Teknik dosyaları yukarıda belirtildiği Belle grup Merkez adresinde Ray Neilson tarafından tutulur.**



Vi, **Belle Group Sheen UK, Sheen, Nr. Buxton, Derbyshire, SK17 0EU, GB**, potvrđujem, že v prípade výrobkov uvedených v tomto osvedčení je kúpil od autorizovaného dealera Belle skupinu v rámci EHS, že spĺňa nasledujúce smernice EHS: 2006/42/CE (táto smernica nahradza smernicu 98/37/ES) (Elektromagnetická kompatibilita Smernica 2004/108/CE v znení 89/336/EEC, 92/31/EEC & 93/68 EHS). Odpadových elektrických a elektronických zariadeniach (OEEZ), 2002/96/CE, nízkonapätové smernice 2006/95/CE, BS EN ISO 12100-1:2003 Bezpečnosť strojových zariadení a súvisiace harmonizované normy, prípadne. Hlukových emisii v súlade so smernicou 2000/14/ES príloha VI a 2005/88/ES, na stroje podľa článku 12 notifikovaný orgán **AVT Reliability, Unit 2 Easter Court, Europa Boulevard, Warrington, Cheshire, WA5 7ZB, GB**.  
**Hluk Technické súbory sú držané Ray Neilson v sídle skupiny Belle Office adresu, ktorá je uvedené vyššie.**

TYP PRODUKU .....	TIPUL PRODUSULUI .....	A TERMÉK TÍPUSA .....
MODEL .....	MODEL .....	MODELL .....
SERI ČÍSL .....	SERIA .....	GYÁRI SZÁM .....
DATUM VÝROBY .....	DATA FABRICARII .....	GYÁRTÁSI IDŐ .....
NAMĚŘENÁ HL. HLUKU / .....(GARANTOVANÁ)	NIVEL DE ZGOMOT MASURAT / .....(GARANTAT)	A MÉRT HANGERŐSZINT / .....(GARANTÁLT)
HMOTNOST .....	GREUTATEA .....	SÚLY .....
TIP PROIZVODA .....	ÜRÜN TIPLI .....	TYP PRODUKTU .....
MODEL .....	MODEL .....	MODEL .....
SERUJSKI Br. ....	SERI NUMARASI .....	SÉRIOVÉ ČÍSLO .....
DATUM PROIZVODNJE .....	ÛRETIM TARIHI .....	DÁTUM VÝROBY .....
NIVO SNAGE ZVUKA IZMJEREN / .....(GARANTIRANO)	SES SEVIYE ÖLÇÜMÜ / .....(GARANTI EDILEN)	NAMERANÁ HLADINA HLUKU / .....(GARANTOVANÁ)
TEŽINA .....	AĞIRLIĞI .....	HMOTNOST .....

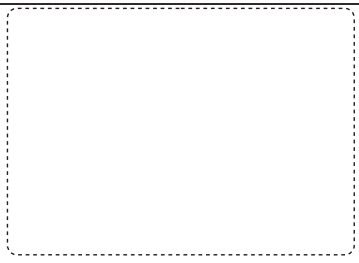

Podpešal:  
Semnat de:  
Alăřás:  
Potpisao:  
Imzlayan:  
Podpisal:

**Ray Neilson**

**Generální ředitel – jménem BELLE GROUP (SHEEN) UK**  
**Director General - in numele BELLE GROUP (SHEEN), UK**  
**Ûgyvezető igazgató - A BELLE GROUP (SHEEN) UK nevében**  
**Izvršni Direktor – U ime BELLE GROUP (SHEEN) UK**  
**Yönetici - BELLE GROUP (SHEEN) UK adına.**  
**Generálny riaditeľ – menom BELLE GROUP (SHEEN) UK**

<b>Místo Deklarace</b> - Sheen, Nr. Buxton, Derbyshire, SK17 0EU, UK	<b>Datum Deklarace</b> - 2012 .....
<b>Local declaratiei</b> - Sheen, Nr. Buxton, Derbyshire, SK17 0EU, UK	<b>Data declaratiei</b> - 2012 .....
<b>Kiállítás Helye</b> - Sheen, Nr. Buxton, Derbyshire, SK17 0EU, UK	<b>Kiállítás Ideje</b> - 2012 .....
<b>Mjesto izjave o usklađenosti</b> - Sheen, Nr. Buxton, Derbyshire, SK17 0EU, UK	<b>Datum izjave o usklađenosti</b> - 2012 .....
<b>Declaration Yeri</b> - Sheen, Nr. Buxton, Derbyshire, SK17 0EU, UK	<b>Declaration Tarihi</b> - 2012 .....
<b>Miesto Deklarácie</b> - Sheen, Nr. Buxton, Derbyshire, SK17 0EU, UK	<b>Dátum Deklarácie</b> - 2012 .....

This manual has been written to help you operate and service the TDX 650 Roller safely. This manual is intended for dealers and operators of the TDX 650 Roller .

## Foreword

The '**Machine Description**' section helps you to familiarise yourself with the machine's layout and controls.

The '**Environment**' section gives instructions on how to handle the recycling of discarded apparatus in an environmentally friendly way.

The '**General Safety**' and '**Health and Safety**' sections explain how to use the machine to ensure your safety and the safety of the general public.

The '**Operating Instructions**' section helps you with the setting up and use of the machine.

The '**Trouble Shooting Guide**' helps you if you have a problem with your machine.

The '**Service & Maintenance**' section is to help you with the general maintenance and servicing of your machine.

## Directives with regard to the notations.

Text in this manual to which special attention must be paid are shown in the following way:



### CAUTION

*The product can be at risk. The machine or yourself can be damaged or injured if procedures are not carried out in the correct way.*



### WARNING

*The life of the operator can be at risk.*

## WARNING



### WARNING

*Before you operate or carry out any maintenance on this machine **YOU MUST READ and STUDY** this manual.*

**KNOW** how to safely use the unit's controls and what you must do for safe maintenance. (NB Be sure that you know how to switch the machine off before you switch on, in case you get into difficulty.)

**ALWAYS** wear or use the proper safety items required for your personal protection. If you have **ANY QUESTIONS** about the safe use or maintenance of this unit, ASK YOUR SUPERVISOR OR CONTACT: **ALTRAD BELLE (UK): +44 (0) 1298 84606**

## Contents

How to use this manual.....	6
Warning .....	6
Technical Data .....	7
Decals .....	8 - 9
Machine Description.....	10
General Safety .....	10
Health and Safety.....	11
Pre-Start Checks .....	11
Environment .....	11
Start & Stop Procedure .....	12
Operating the TDX Roller.....	13
Service & Maintenance .....	13 - 15
Wiring Diagram.....	16
Long Term Storage.....	17
Warranty.....	17
Spare Parts Information .....	17
Certificate of Conformity.....	2

# Technical Data

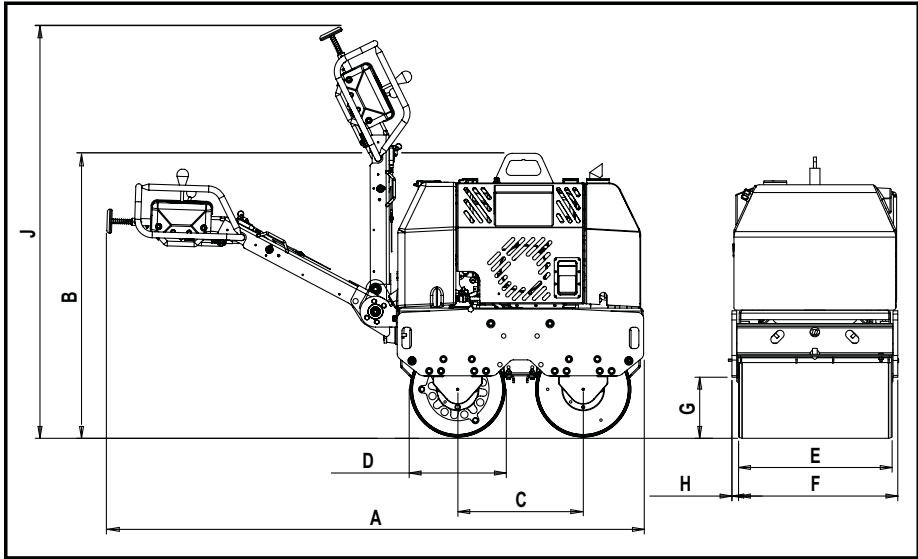

Model	TDX 650
Weight* - Kg	775
A - Overall Length - mm	2272
B - Overall Height - mm	1093
C - Wheel Base - mm	530
D - Drum Diameter - mm	402
E - Drum Width - mm	650
F - Overall Width - mm	702
G - Curb Clearance - mm	258
H - Lateral Overhang - mm	28
I - Height at Storage - mm	1730
Travel Speed (F'wrd) - m/m (km/h)	0 - 65 (0 - 3.9)
Travel Speed (Rev) - m/m (km/h)	0 - 35 (0 - 2.1)
Vibration Frequency - v.p.m	3300
Centrifugal Force - kN	20
Water Tank Capacity - Ltr	65
Oil Tank Capacity - Ltr	18
Engine	YANMAR L100N
Type	4-Cycle Air-Cooled
Fuel	Diesel
Fuel Tank Capacity - Ltr	5.4
Rated Output - Hp (kW)	9 (6.6)
Max. Output - Hp (kW)	10 (7.4)
Starting System	Electric (with Recoil Start back-up option)

\* Weight is without any water in the Water Tank. Water in Tank = 65litres = 65Kg

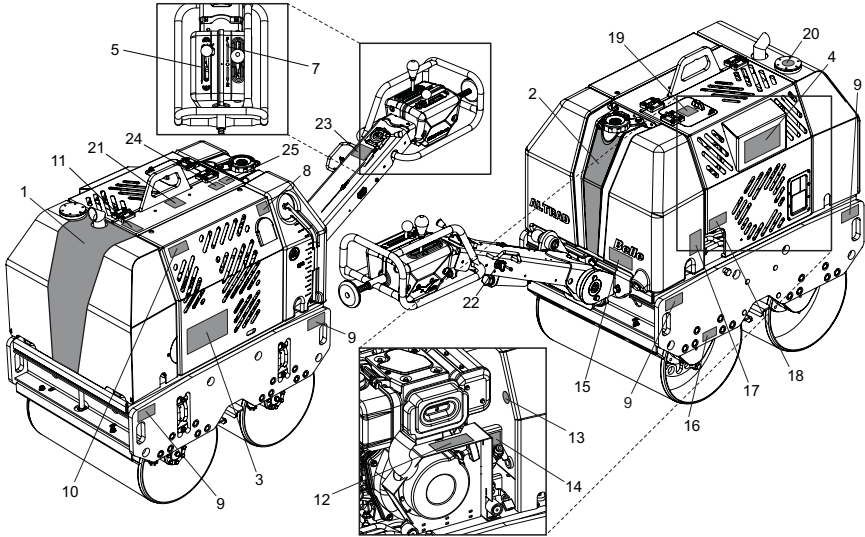

**Items 1 to 4 - Branding Decals**

Branding Decals to identify the TDX Roller.

**Item 5 - Vibration Lever Decal**

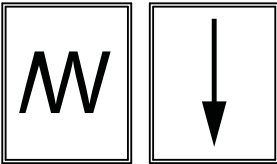

**Vibration Engaged**

**Vibration Disengaged**

**Item 6 - Caution/Read Manual Decal**

**CAUTION!** Please read the Operators Manual before using the machine.

**Item 7 - Forward/Reverse Lever Decal**

Lever to change the direction of the machine. **F = Forward, R = Reverse, ● = Neutral.**

**Item 8 - Maintenance Decal**

Indicates the canopy can be removed for internal maintenance purposes.

**Item 9 - Strapping Decal**

Identifies which areas can be used for strapping the machine to a hoist for lifting or strapping down during transportation.

**Item 10 - Crushing Decal**

**CAUTION!** Canopy could cause crushing if care not taken.

**Item 11 - Hot Surface Decal**

**CAUTION!** Beware of hot surfaces around the Hydraulic Tank and Exhaust area.

**Item 12 - Engine Oil Fill Decal**

Indicates where to top-up the Engine Oil and where to check the Engine Oil level.

**Item 13 - Hydraulic Oil Level Decal**

Indicates the position of the Hydraulic Oil Gauge which shows the level of Hydraulic Oil within the tank.



**Item 14 - Engine Oil Type Decal**

Explains the type of oil which should be used to fill the engine.

**Item 15 - Water Drain Decal**

If the forecasted ambient temperature is below freezing, the Water Tank must be drained using the Drain Plug.

**Item 16 - Park Brake Decal**

Shows the position of the Parking Brake. The Parking Brake must be applied when the machine is not in use.

**Item 17 - Spraybar Tap Decal**

Shows the position of the Spraybar Taps and also which Tap is for which Spraybar.

**Item 18 - Door Stay Decal**

Gives instructions on how to open the Engine Canopy and locate the Door Stay safely.

**Item 19 - Diesel Only Decal**

Engine must be filled with Diesel ONLY!

**Item 20 - Hydraulic Oil Decal**

Hydraulic Oil tank filler cap location.

**Item 21 - Lifting Eye Decal**

Lifting Eye for use with a Sling or Mechanical Hoist.

**Item 22 - Ignition Key Decal**



**OFF**

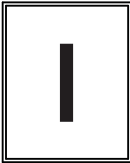

**ON**

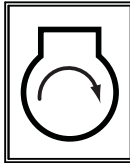

**START**

**Item 23 - Throttle Decal**



**Max. RPM  
Position**

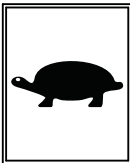

**Idle  
Position**



**Emergency  
Stop  
Position**

**Item 24 - Safety Decal**



**Wear Ear  
Protection**



**Wear Eye  
Protection**



**Wear  
Protective  
Footwear**

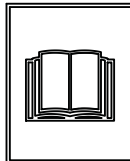

**Please  
Read  
Operators  
Manual**

**Item 25 - Noise Level Decal**

Guaranteed Sound Power Level of the machine in dB(A).

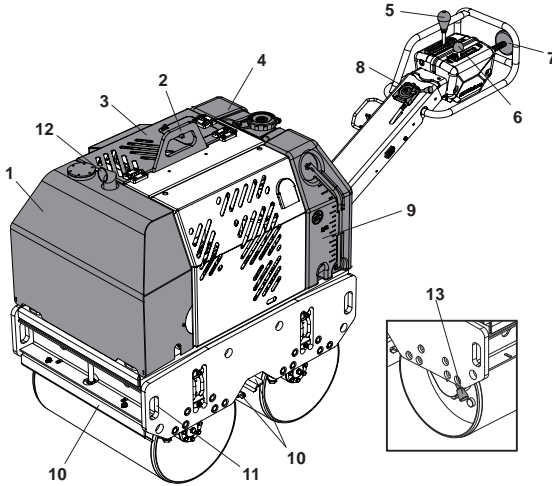

1. Hydraulic Oil Tank.
2. Lifting Eye.
3. Engine Canopy.
4. Water Tank.
5. Forward / Reverse Lever.
6. Vibration Lever.
7. Safety Lever For Reverse Motion.
8. Throttle Lever
9. Water Level Gauge
10. Scraper Bars
11. Strapping Points.
12. Exhaust.
13. Parking Brake

For your own personal protection and for the safety of those around you, please read and ensure you fully understand the following safety information. It is the responsibility of the operator to ensure that he/she fully understands how to operate this equipment safely. If you are unsure about the safe and correct use of the TDX 650 Roller, consult your supervisor or ALTRAD Belle.



## CAUTION

*Improper maintenance can be hazardous. Read and Understand this section before you perform any maintenance, service or repairs.*

- This machine must only be used for its intended purpose.
- This machine must be operated only by well-trained personnel.
- The owner of this machine must observe, and train the user of the machine to observe, the effective Labor Protection Regulation in the country of application.
- Use suitable lifting equipment to lift the machine.
- This machine must be operated on the ground where stability is guaranteed. When working near the rim of excavated trenches, use the machine properly so that the machine may not collapse or fall down.
- If the surface to be compacted is on a slope, great care must be taken when controlling the machine's direction of travel. Always work up and down a slope, not across. If the machine is parked on a slope, always apply the Parking Brake Lever.
- Cordon off the work area and keep members of the public and unauthorized personnel at a safe distance.
- Personal Protective Equipment (PPE) must be worn by the operator whenever this equipment is being used (see Health & Safety)
- Make sure you know how to safely switch this machine OFF before you switch it ON in case you get into difficulty.
- Always switch OFF the engine before servicing it.
- During use the engine becomes very hot, allow the engine to cool before touching it.
- Never leave the engine running and unattended.
- Never remove or tamper with any guards fitted, they are there for your protection. Always check guards for condition and security. If any are damaged or missing, DO NOT USE THE MACHINE until the guard has been replaced or repaired.
- Do not operate the machine when you are ill, feeling tired, or when under the influence of alcohol or drugs.
- This machine is designed to eliminate the possible risks arising from the use of it. However, risks DO reside, and these residual risks are not clearly recognizable, and may cause personal injury or property damage, and possible death. If such unpredictable and unrecognizable risks become apparent, the machine must be stopped immediately, and operator or his supervisor must take appropriate measure to eliminate such risks. It is sometimes necessary that the manufacturer must be informed of such event for future counter measuring.

## Fuel Safety



## CAUTION

*Fuel is flammable. It may cause injury and property damage. Shut down the engine, extinguish all open flames and do not smoke while filling the fuel tank. Always wipe up any spilled fuel.*

- Before refuelling, switch off the engine and allow it to cool.
- When refuelling, DO NOT smoke or allow naked flames in the area.
- When refuelling, use proper funnel, and avoid spilling over the engine.
- Spilt fuel must be made safe immediately, using sand. If fuel is spilt on your clothes, change them.
- Store fuel in an approved, purpose made container away from heat and ignition source.

## Vibration

Some vibration from the compaction operation is transmitted through the handle to the operator's hands. The Altrad Belle 'TDX 650' has been specifically designed to reduce hand/arm vibration levels. Refer to Technical Data section for vibration levels and usage times (recommended maximum daily exposure time). **DO NOT** exceed the maximum usage times.

## PPE (Personal Protective Equipment).

Suitable PPE must be worn when using this equipment i.e. Safety Goggles, Gloves, Ear Defenders, Dust Mask and Steel Toe capped footwear (with anti-slip soles for added protection). Wear clothing suitable for the work you are doing. Always protect skin from contact with concrete.

## Dust.

The compaction process can produce dust, which may be hazardous to your health. Always wear a mask that is suited to the type of dust being produced.

## Fuel.

Do not ingest fuel or inhale fuel vapors and avoid contact with your skin. Wash fuel splashes immediately. If you get fuel in your eyes, irrigate with copious amounts of water and seek medical attention as soon as possible.

## Exhaust Fumes.

Do not operate your TDX 650 Roller indoors or in a confined space, make sure the work area is adequately ventilated.



### **WARNING**

*The exhaust fumes produced by this equipment are highly toxic and can kill!*

# Pre-start Checks

## Pre start-up inspection.

The following Pre-start-up inspection must be performed before the start of each work session or after every four hours of use, whichever is first. Please refer to the service section for detailed guidance. If any fault is discovered, the 'TDX 650' must not be used until the fault is rectified.

1. Thoroughly inspect the machine for signs of damage.
2. Check hoses, filler openings, drain plugs and any other areas for signs of leakage. Fix any leaks before operating.
3. Check the engine oil level and top up as necessary.
- 3a. Place the machine on a level surface, and check the oil level of the engine.
- 3b. Remove the oil gauge, and observe that the oil is up to the rim of the filler port. Use proper engine oil with the proper viscosity (Please see the SAE Service Grade Viscosity Chart in the Servicing section)
4. Check the engine fuel level and top up as necessary. Use clean fuel. Use of contaminated fuel may damage the fuel system.
5. Check the Air Filter is clean. Excessive dirt/dust accumulation within the filter element will cause erratic engine operation. Clean the air filter element when it is contaminated. (See Servicing Section)
6. Check the function of Operators Controls. Make sure that the Drive lever, Vibration lever, Throttle Lever, Park Brake Lever, and the safety device for the reverse motion moves smoothly.

# Environment

## Safe Disposal.



Instructions for the protection of the environment. The machine contains valuable materials. Take the discarded apparatus and accessories to the relevant recycling facilities.

Component	Material
Operator Handle	Steel
Main Frame	Steel
Hydraulic Oil Tank	Steel
Water Tank	Poly-Ethylene
Cover	Poly-Ethylene
Hydraulic Pump	Steel and Aluminium
Hydraulic Motor	Steel
Engine	Steel and Aluminium
Various parts	Steel, Aluminium & Rubber



**CAUTION** DO NOT let your hands off from the Starting Handle during the Starting procedures.

Before starting the engine, make sure that the Drive Lever is at Neutral, Vibration Lever is at OFF, and the Parking Lever is at ON position.

1. Open the fuel tap at the engine.
2. Move the Throttle Lever on the Operation Handle to the Full Throttle (Hare) position.

#### Start the Engine – Electric Start

- 3a. Turn the Key Switch at the Throttle Lever to Start  position, and hold it until the engine starts. **DO NOT** crank for an extended period. Maximum 10 secs.
- 3b. After the engine has been started, make sure that the key is set to ON (I) position during the operation. (Setting the Key Switch to OFF (0) position would not allow the generator to charge the battery.)

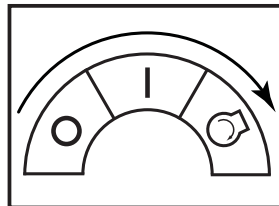

#### Start the Engine – Manual Start

- 4a. Grasp the recoil starter handle.
- 4b. Pull the handle out slowly until you feel Istrong resistance.
- 4c. Slowly return the recoil starter to the initial position.
- 4d. Push the decompression lever down and then release it. The decompression lever will automatically return to the original position when the engine starts.
- 4e. Grasp the recoil starter handle.
- 4f. Pull the handle all the way out with a strong and even motion. Use two hands if necessary.
- 4g. Slowly return the starter handle to the initial position.
- 4h. If the engine does not start, repeat the procedure from step 4b.
5. Move the Throttle Lever to LOW position, and let the engine run at idle for a few minutes to warm up.
6. After the engine has warmed up, the machine is ready for operation.
7. Move the throttle lever to the high speed "H" position quickly to prevent damage from occurring to the clutch. The "Full Throttle" position of this machine has been preset at the factory to achieve optimum machine performance. **DO NOT** alter this setting since premature wear or tear can result, and both engine and machine warranty will be automatically voided.
8. Move the Parking Brake Lever to the right to disengage it.

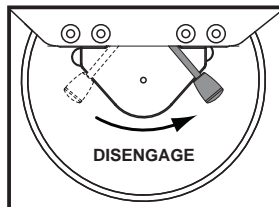

**NOTE:** Negligence to disengage the Parking Brake before attempting to drive the machine forward or reverse will result in the severe damage to the parking brake mechanism as well as the drive system.

#### 9. Operators Control

##### 9a. Throttle Lever

Always keep the Throttle Lever at High position during the operation. **DO NOT** attempt to alter the travel speed by changing the engine revolution.

##### 9b. Drive Lever

Move the Drive Lever forward to drive the machine forward. For reverse motion, move the lever backward.

##### 9c. Vibration Lever

By shifting the Vibration Lever to ON position, the vibration mechanism will be engaged, and produce the vibration.

#### 10. Stopping the Engine

11. In preparation for stopping the engine, move the throttle lever to LOW position.
12. Allow the engine to idle for 1-3 minutes.
13. Move the Throttle Lever to STOP position to stop the engine. Then, set the Key Switch to "OFF" position. The buzzer will sound when the Key Switch is set to ON while the engine is stopped.
14. Close the Fuel tap
15. Apply parking brake by swinging the Parking Brake Lever to the left.

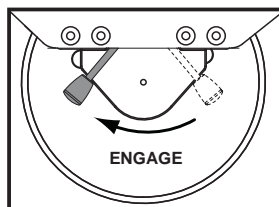
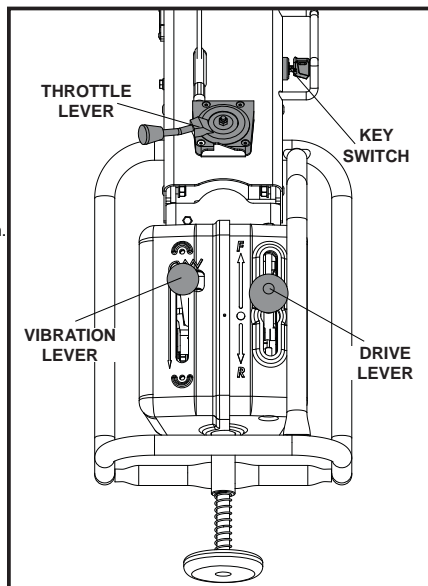

- **Having carried out the checks listed in the 'pre start' section, you may start the engine.**  
The ALTRAD Belle TDX 650 Roller is fitted with a centrifugal clutch; this allows the engine to run at idle without driving the Hydraulic pump.
- As the engine speed is increased the clutch will engage and the engine will drive the Hydraulic Pump to send the hydraulic power to drive the drums, and to drive the vibration mechanism as well. To avoid any damage to the centrifugal clutch, move the throttle lever quickly from L to H position. For correct operation, the engine speed should be set to maximum during the compaction operation
- Avoid operating the machine on a fully compacted, hard, or non-yielding surface. Otherwise, the bearings and other mechanical components will be damaged, and the life of the machine will be greatly reduced.
- When working on a steep slope, pay extra care in operating the machine so that the machine roll down the slope. Always work up or down the slope. Do not work across the slope. If the machine is parked on a slope, always apply the Parking Brake Lever.
- When the machine is going in reverse, make sure not to stand behind the Operation Handle. Always walk along the Operation Handle and face toward the direction of travel.
- **Lifting**  
Where it is necessary to use lifting equipment to position the TDX 650, make sure the lifting equipment has a WLL (Working Load Limit) suitable for the machine's weight (see Technical Data table). Attach suitable chains or slings **ONLY** to the lifting points provided at the centre of the machine (Lifting Eye) or at each corner of the machine (Strapping Points).
- **TRANSPORTATION**  
**Transportation on a vehicle.**  
Make sure to lock the Handle and use proper slopes of sufficient width, length, and strength on loading to and unloading from the vehicle.
- Apply the parking brake, and tie the machine firmly to the vehicle during the transportation.

## Servicing



### Maintenance

The ALTRAD Belle TDX 650A is designed to give many years of trouble free operation. It is, however, important that the simple regular maintenance listed in this section is carried out. It is recommended that an approved ALTRAD Belle dealer carries out all major maintenance and repairs. Always use genuine ALTRAD Belle replacement parts, the use of spurious parts may void your warranty. Before any maintenance is carried out on the machine, switch off the engine and remove Key from the Key Switch

Always set the machine on level ground to ensure any fluid levels will be correctly read. Only use recommended oils (see page 15).

### Servicing the Engine

Service the engine according to the engine manufacturer's specifications.  
Refer to the engine operation and maintenance manual.

**Note:** When the Maintenance Cover has been removed, ensure that all Bolts are securely fastened when re-fitting. **DO NOT** restart the machine with guards removed.

### Maintenance: Every 8 hours or daily

1. Check for loose bolts and nuts, retighten if necessary.
2. Check and clean the air filter element, re-lube the element in accordance with the engine manufacturer's recommendations. If operating conditions are unusually dusty and severe, filter element cleaning should be done more frequently.
3. Check Engine Oil Level before operation.

### Maintenance: After first 50 hours and every 200 hours thereafter

1. Change the Engine Oil - see procedure on page 15.

**Maintenance: Every 50 hours or weekly**

1. **Check for the tension of Drive Belt**
  - 1a. Loosen four bolts, which fixes the Pump Bracket, and turn the Adjust Bolt until proper tension is achieved. The belt should deflect by 5mm at the center between Centrifugal clutch and pump pulley.
  - 1b. Tighten four bolts at the Pump Bracket. When the belt is worn out or cracked, renew the belt.
2. **Adjust the clearance of Scraper**
  - 2a. Remove the Scraper, and wipe of all the dirt, mud, and asphalt.
  - 2b. Refit the Scraper to the Scraper Bracket and fix it with suitable clearance (1mm) from the drum.
3. **Water Tank**
  - 3a. Drain all the water, and clean the inside of the tank using a hose
4. **Sprinkler Nozzle**
  - 4a. Remove the Cap from the nozzle, and clean the inside of Sprinkler Nozzle.
5. **Moving Parts**
  - 5a. Feed grease to the Rod End of the Drive/Vibration Cable.
  - 5b. Re-Grease the Greasing Points in the Operation Handle.

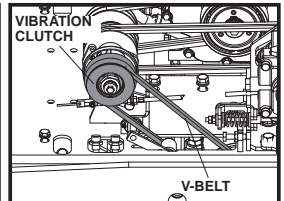
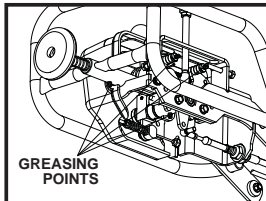
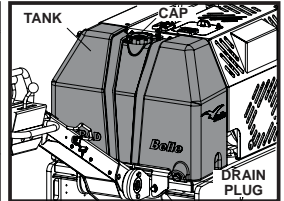
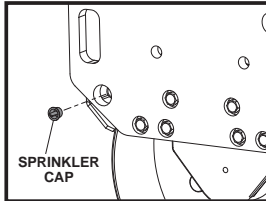
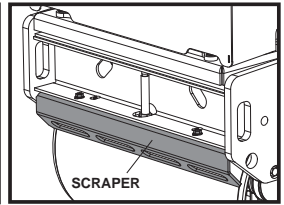
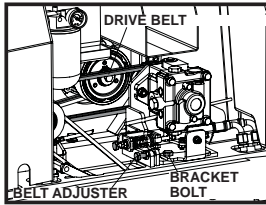

**Maintenance: Every 100 hours**

1. **Vibration Clutch Mechanism**
  - 1a. Check to confirm that the Vibration Clutch Mechanism works properly.
  - 1b. Feed grease to the moving part.
  - 1c. Check the condition of V-belt. When it is worn out or cracked, renew the belt.

**Maintenance: Every 500 hours**

1. Replace the Hydraulic Oil Filter Element at every 500 hours of operation. Use Genuine Filter element.

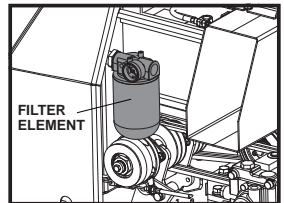

**Maintenance: Every 800 hours**

1. Replace the Hydraulic Oil. Flush off the tank before supplying the new Hydraulic Oil. To vent the air in the hydraulic system, leave the Tank Cover open, and run the engine at its maximum speed without operating the Drive Lever and Vibration Lever for 10 minutes. Then, refit the Tank Cover.

**Adjusting The Neutral Setting Of Drive Lever**

The neutral position of the Drive Lever may be shifted due to the vibration or wear of the drive cables. To adjust the Neutral Setting, follow the instructions below;

1. Place the machine on a level surface.
2. Make sure that the engine is turned off.
3. Remove the Nut which fix the Rod End of Drive Cable to the Drive Lever.



**WARNING**

*Do not attempt to start the engine when this nut is off its position. Machine may move suddenly and irrationally without the capability of being controlled with the Drive Lever, which may cause severe injury or property damage.*

4. Loosen the Lock Nut at the Rod End.
5. Turn the Rod End either clockwise or counterclockwise depending upon the direction of shifted neutral position.
6. Refit the Rod End to the Drive Wire, and secure it with nut.
7. Start the engine, and increase the engine revolution to maximum. Observe to see if the neutral position has been properly adjusted.
8. If not, stop the engine, remove the nut, and repeat the procedure 5 to 7 until the neutral position is properly set.
9. When the neutral position is correctly adjusted, apply Loctite to the Nut, which fix the Rod End, and tighten it. Then, tighten the Lock Nut at the rod end.

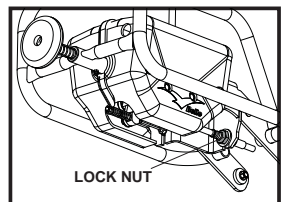

## Hydraulic Oil

- Total EP32, Shell Tellus T37, MOBIL DTE15 or ESSO Unipower, XL46.

## Engine Oil

Select the appropriate engine oil viscosity based on the ambient temperature and use the SAE Service Grade Viscosity Chart below. This machine is filled with SAE 15W-40 at the factory.

### Engine Oil Specifications

Use an engine oil that meets or exceeds the following guidelines and classifications:

#### Service Categories

- API Service Categories CD or higher.
- ACEA Service Categories E-3, E-4 and E-5
- JASO Service Category DH-1

#### Definitions

- API Classification (American Petroleum Institute)
- ACEA Classification (Association des Constructeurs Européens d'automobiles)
- JASO (Japanese Automobile Standards Organisation)

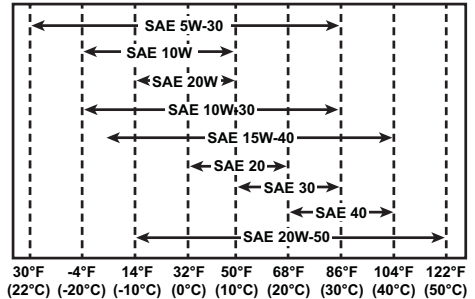

### Engine Oil Change Procedure

1. Ensure the Roller is on a level surface and the operating handle in the storage position. Apply the Park Brake.
2. Open hinged side canopy, ensuring door stay is correctly engaged.
3. Cut the cable tie which secures the oil drain hose to the water tank spine plate and then pull the hose clear of the side of the chassis.
4. Remove the bung from the end of the oil drain hose using 2 x 22mm Spanners and drain the oil into a suitable container.
5. Once fully drained, re-fit the bung to the hose and attach the hose to the water tank spine plate using a cable tie.
6. Remove the oil fill plug which is situated to the right of the recoil on the engine using a 28mm Spanner.
7. Use a funnel and pour the oil into the filler hose. Care must be taken whilst filling to ensure capacity is not exceeded. Use the dipstick on the left hand side of the engine to check the oil level.
8. Re-fit the oil fill plug and close the canopy.
9. Check that the machine functions correctly.

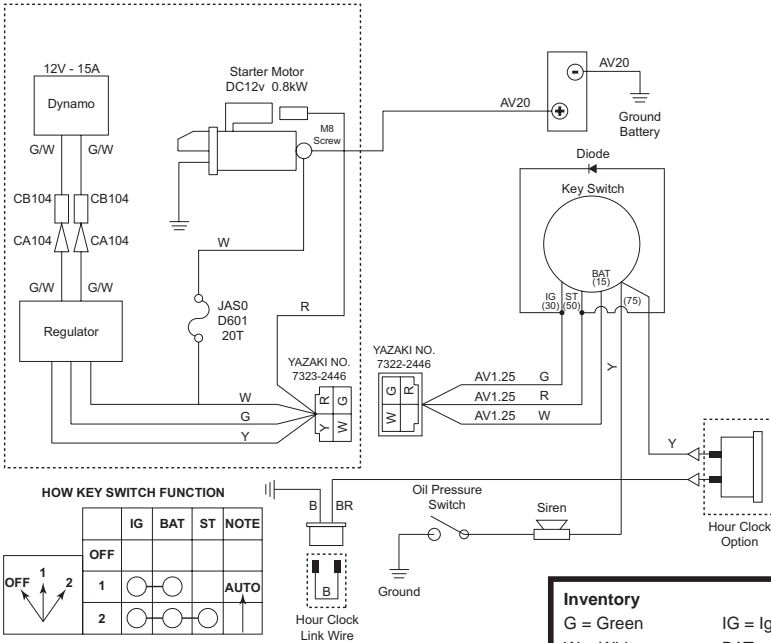

**Inventory**

G = Green	IG = Ignition
W = White	BAT = Battery
Y = Yellow	ST = Start
R = Red	BK = Black
BL = Blue	SB = Sky Blue
OR = Orange	BR = Brown

1. For long-term storage, empty the fuel from the Fuel Tank by either sucking the remaining fuel out from the Fuel Inlet port or from the Fuel Filter after the filter cup has been removed.
2. Clean the Air Cleaner Element.
3. Clean-up the oil and dust accumulation on all rubber parts.
4. Clean the base plate and apply a light coating of oil to prevent rust formation.
5. Cover the machine and store it in a dry place.
6. The Operation Handle can be stood up for storage. Pull the Stopper, and raise the handle. Make sure that the Stopper securely holds the Operation Handle.

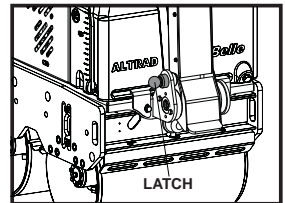



Your new Altrad Belle TDX 650 is warranted to the original purchaser for a period of one-year (12 months) from the original date of purchase.

The Altrad Belle warranty is against defects in design, materials and workmanship.

The following are not covered under the Altrad Belle warranty:

1. Damage caused by abuse, misuse, dropping or other similar damage caused by or as a result of failure to follow assembly, operation or user maintenance instructions.
2. Alterations, additions or repairs carried out by persons other than Altrad Belle or their recognised agents.
3. Transportation or shipment costs to and from Altrad Belle or their recognised agents, for repair or assessment against a warranty claim, on any machine.
4. Materials and/or labour costs to renew, repair or replace components due to fair wear and tear.

The following components are not covered by warranty.

- Engine air filter
- Engine spark plug

Altrad Belle and/or their recognised agents, directors, employees or insurers will not be held liable for consequential or other damages, losses or expenses in connection with or by reason of or the inability to use the machine for any purpose.

### Warranty Claims

All warranty claims should firstly be directed to Altrad Belle, either by telephone, by Fax, by Email, or in writing.

#### For warranty claims:

Tel : +44 (0)1298 84606,

Fax : +44 (0)1298 84073,

Email : [Warranty@belle-group.co.uk](mailto:Warranty@belle-group.co.uk)

#### or Write to:

Altrad Belle Warranty Department,  
Sheen, Nr. Buxton  
Derbyshire  
SK17 0EU  
England

#### Warranty Registration:

In the bid for ALTRAD Belle to become greener and more eco friendly, we have now introduced online Warranty registration. To access the registration page of our website, please use the following address:-

[http://www.bellegroup.com/index.php?p=warranty\\_registration](http://www.bellegroup.com/index.php?p=warranty_registration)

Alternatively, please scan the adjacent QR Code (Quick Response Code) using your smartphone to access the registration page.



# Spare Parts Information

### KEY



**USE  
LOCTITE**



**USE  
OIL**



**USE  
SILICONE**

For information regarding Spare Parts availability for this machine, please visit [www.Belle247.com](http://www.Belle247.com) or contact the ALTRAD Belle using the following contact details:-

Tel:- +44 (0)1298 84606

Fax:- +44 (0)1298 84722

Email:- [sales@ALTRAD-Belle.com](mailto:sales@ALTRAD-Belle.com)

#### **# - Colour Option 1**

Part No. + S = Orange (Eg. 981/05100S)

Part No. + G = Green

Part No. + B1 = Blue

Part No. + R1 = Red

Part No. + Y = Yellow

Part No. + Y2 = Yellow

#### **## - Colour Option 2**

Part No. + GR = Grey (Eg. 981/03200GR)

Part No. + GR2 = Quartz Grey

Part No. + BL = Black

Part No. + W = White